

	Robot model	Controller	Controlled axes	Max. load capacity at wrist [kg]	Repeatability [mm]	Mechanical weight [kg]	Reach [mm]	Motion range [°]						Maximum speed [°/s]						J4 Moment [Nm]/ Inertia [kgm ²]	J5 Moment [Nm]/ Inertia [kgm ²]	J6 Moment [Nm]/ Inertia [kgm ²]	IP Rating
								J1	J2	J3	J4	J5	J6	J1	J2	J3	J4	J5	J6				
M-900iA	200P	R-30iA	6	200	± 0.3	2670	3507	360	180	180	720	230	720	110	95	95	85	85	165	2200/413.2	2200/413.2	715/392	Wrist & J3 arm IP67, body IP54. Option: movable parts IP66, main body IP56
	260L		6	260	± 0.3	1800	3100	360	150	211	720	250	720	100	105	95	120	120	200	1666/188/313 ⁱ⁾	1666/188/313 ⁱ⁾	715/118/225 ⁱ⁾	
	350		6	350	± 0.3	1720	2650	360	150	223	720	250	720	100	95	95	105	105	170	1960/235/392 ⁱ⁾	1960/235/392 ⁱ⁾	891.8/157/352 ⁱ⁾	
	400L		6	400	± 0.5	3150	3625	360	154	160	720	244	720	80	80	80	100	100	160	2744/510	2744/510	1715/320	
	600		6	600	± 0.3	2800	2832	360	154	160	720	244	720	80	80	80	100	100	160	3381/510	3381/510	1725/320	
	600 (700 kg SW)		6	700	± 0.3	2800	2832	360	154	160	720	244	720	80	80	80	100	100	160	3381/1098	3381/1098	1725/320	

i) High Inertia mode

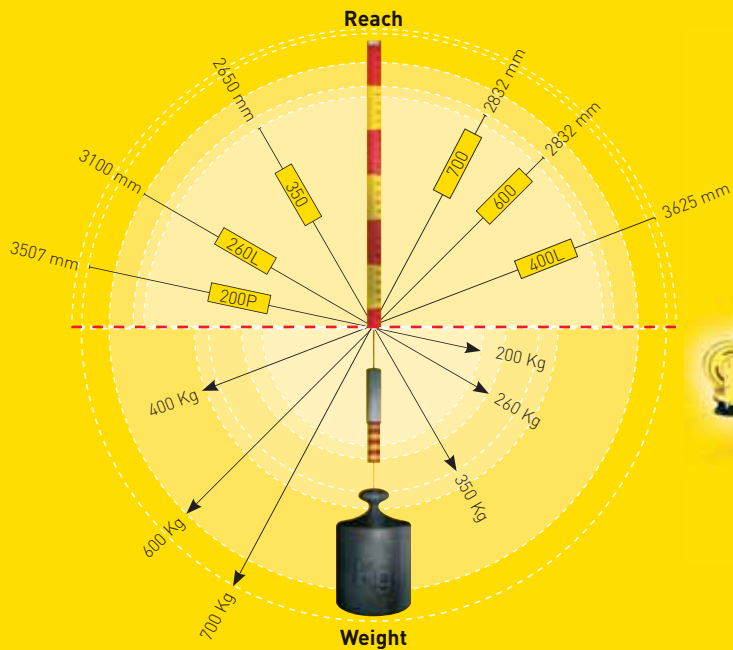

Available in 6 different versions:

- M-900iA/260L: 260 kg, Long arm
- M-900iA/200P: 200 kg, Super long arm, rack mount (press transfer)
- M-900iA/350: 350 kg, Standard model
- M-900iA/400L: 400 kg, Super long arm
- M-900iA/600: 600 up to 700 kg (option)

THE M-900iA 6-AXES ROBOT SERIES HAS ONE OF THE HIGHEST PAYLOADS AVAILABLE IN THE MARKET TODAY, DESIGNED TO HANDLE VERY HEAVY OR MULTIPLE PARTS (200 TO 700 KG PAYLOAD).

FEATURES AND BENEFITS

M-900iA Series, the solution for:

- Heavy duty spot welding
- Handling of heavy work pieces
- Palletising (complete layers)
- Press transfer



M-900iA/260L
M-900iA/350
M-900iA/400L
M-900iA/600/700



M-900iA/260L
M-900iA/350



M-900iA/260L
M-900iA/350



M-900iA/200P

HIGH ALLOWABLE WRIST MOMENT AND INERTIA

- Ability to handle large gripper and heavy payload at high speed
- Flexibility on gripper design (choice of cheaper material improving the robustness of the gripper)
- Improved carrying capability providing higher throughputs

J4 ROTATION AT WRIST - SLIM J3 ARM WITH EQUIPMENT MOUNTING FLANGES

- With hollow drive shafts for the wrist motor the J3 arm is very slim for easy access into narrow spaces.
- The J4 reducer at the end of J4 keeps the whole J3 arm stationary. Axis 4 rotates at end of arm
 - Reliable long-life design - proven in the automotive industry
 - Simple and reliable cable dress out package

ADDITIONAL MOUNTING FACILITY ON J3 ARM

- Capability to mount additional 25 kg on the arm at full payload at wrist
- Equipment mounting close to the wrist on the rigid J3 arm keeps "free" gripper hoses and cables short and avoids wear and tear

COMPACT WRIST: NO MOTORS AND IP67

- No electrical elements at wrist: all motors for wrist motion are mounted on the robot's „shoulder“, J3.
 - Reduced risk of damaging the wrist motors because of high heat or harsh environment
 - Compact design to access narrow spaces
 - High loads and high duty cycles possible thanks to good air cooling of the wrist motors
- Wrist unit sealed against dust and water according to IP67

STANDARD AIR AND ELECTRICAL CONNECTIONS PROVIDED TO AXIS J3

- Integrated air and electrical services from J1 to J3
- Short connections to tool
 - Increased wiring reliability
 - Proven reliability (factory built)

FLOOR AND CEILING MOUNTING M-900iA/260L and M-900iA/350 (ANGLE AND WALL ALSO POSSIBLE)

- Easier access to the machine being serviced
 - Maximised use of the robot work envelope
- Note: the M-900iA/600 is floor mounted.

OPTION: SEVERE DUST LIQUID PROTECTION (SDLP)

- Main body protected from dust and water jets - IP56
- Wrist part dustproof and can be immersed in water - IP67
- Drivetrain (motors, reducers, gear, drive shaft) - IP66
- Anti-corrosive bolts

HIGH MECHANICAL RIGIDITY

Suitable for constant force applications such as routing, cutting, polishing, deburring, etc...

MOTORS DIRECTLY COUPLED TO THE REDUCER

- Simplified mechanical unit
- Reduced breakdown risk
- Compact and reliable solution
- High accuracy and minimum backlash

HOLLOW JOINT CONSTRUCTION

Reduced wear of cable routing as most reducers have hollow construction



M-900iA/400L

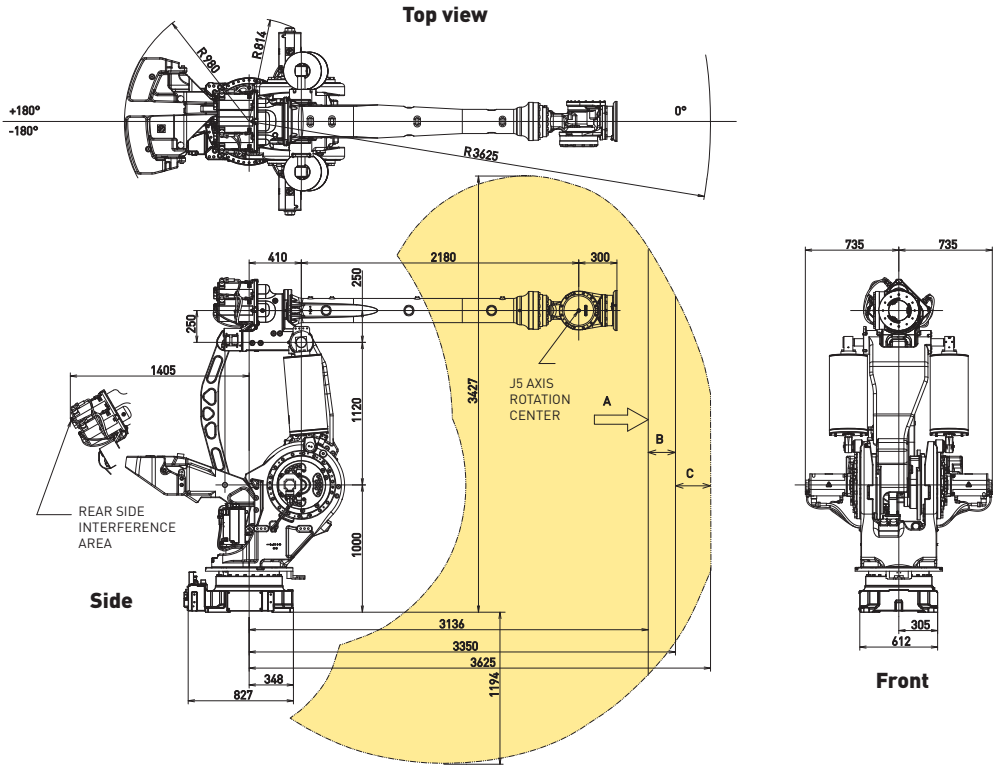

AREA A: ROBOT CAN MOVE WITHOUT RESTRICTION

AREA B: WRIST MOTION IS RESTRICTED SO THAT THE VECTOR FROM THE CENTER OF THE WRIST TO THE COFG OF THE PAYLOAD IS DOWNWARD AND LESS THAN 30 DEGREES FROM THE VERTICAL

AREA C: WRIST MOTION IS RESTRICTED SO THAT THE VECTOR FROM THE CENTER IS DOWNWARD AND VERTICAL R OF THE WRIST TO THE COFG OF THE PAYLOAD

Flange Wrist M-900iA/400L/600

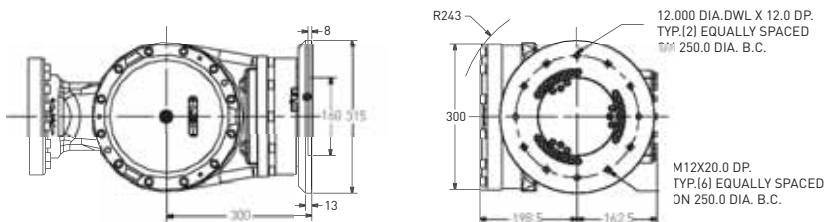

M-900iA/600

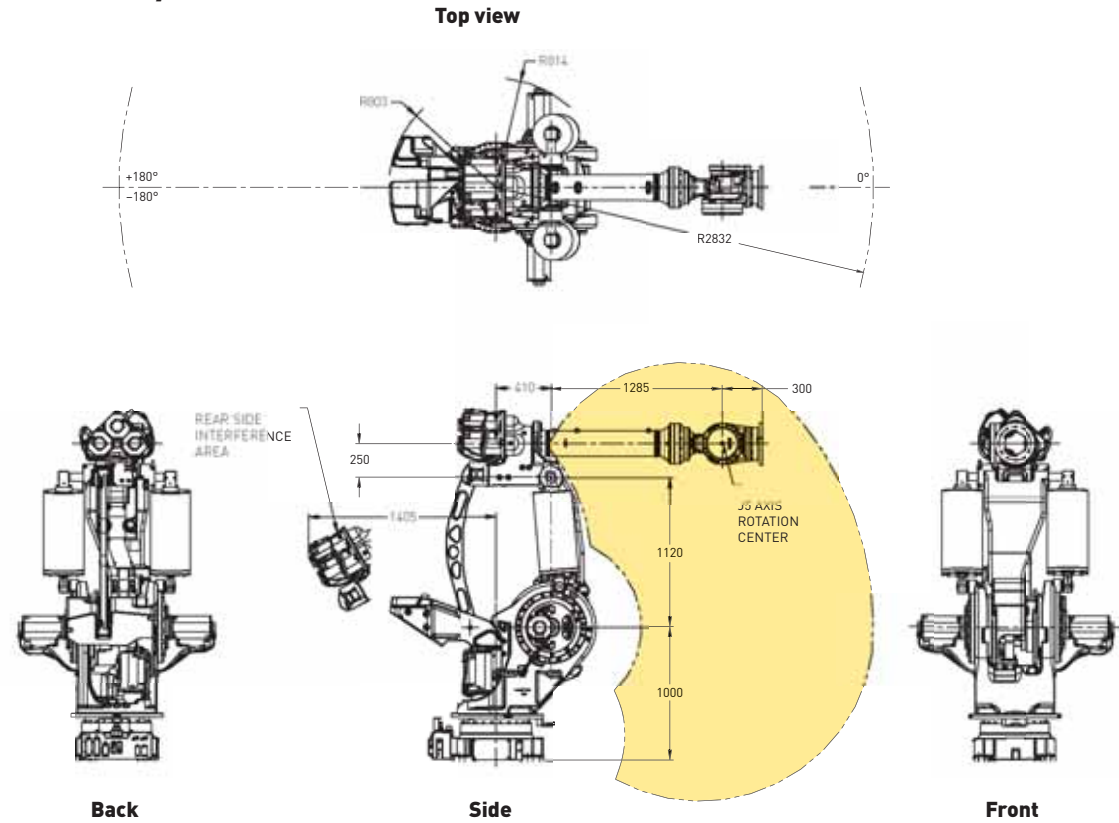

Footprint M-900iA/350/260L/400L/600

